

INSULATED HOT CABINET MODEL H-137-UA-9C

FEATURES AND BENEFITS:

- Fully insulated 3/4 size holding cabinet keeps prepared foods at serving temperatures.
- Powerful, yet efficient, 1500 Watt heating system maintains the right temperature to properly hold products. Heats up to 200°F (93°C).
- Self-contained power top allows interior of cabinet to be hosed-out during cleaning.
- Internal frame in body maintains structural rigidity.
- Body constructed of non-corrosive, Hi-Tensile aluminum for strength and ease of mobility. One piece extended base protects cabinet body.
- Smooth interior coved corners prevent food particle/grease buildup.
- Safety-conscious anti-microbial latch protect against spreading germs.
- Self-closing insulated door prevents temperature loss; magnetic door gasket for proper seal. Field reversible for flexibility.
- Standard with right hand hinging; left hand hinging available upon request.
- Full length extruded door handle for "easy open"; positive catch secures door during transport.
- Recessed push/pull handle on both sides prevents damage to walls; allows easy maneuvering.
- Nine sets of chrome plated wire universal angles accommodate a large variety of pan sizes on adjustable 1-1/2" centers.
- Heavy duty 5" swivel casters, two with brakes. Provides mobility when fully loaded.



H-137-UA-9C



ACCESSORIES and OPTIONS (Available at extra cost):

- Key Lock Handle
- Tempered Glass Door Windows
- Door with Magnetic Latch
- Extra Universal Angles
- Change from standard chrome plated wire angles to angles designed for transporting
- Change from chrome plated wire angles to extruded aluminum or formed stainless steel angles.
- Corner Bumpers
- Perimeter Bumper
- Floor Lock (for use with 5" casters)
- Various Caster Options
- Removable Cord Set
- 208 or 240 Volt Service
- Food Safe Digital Thermometer

See page B-20 for accessory details.

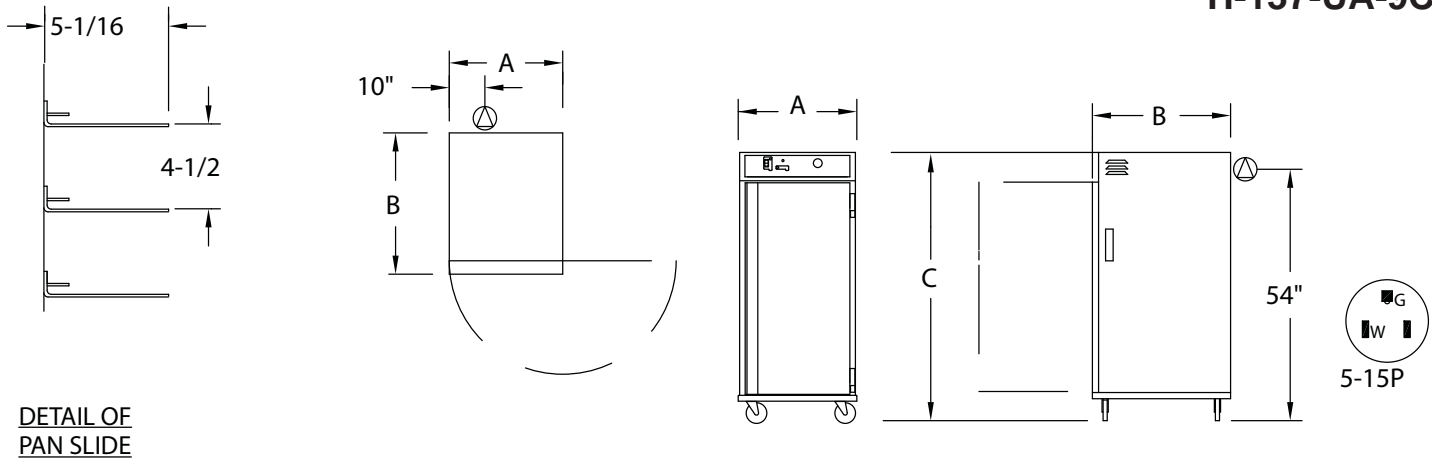

DETAIL OF PAN SLIDE

CRES COR MODEL NO.	PAN			DIM "A"	DIM "B"	DIM "C"	INSIDE DIMENSIONS				WEIGHT ACT.
	CAP/ANGLES	SIZE		WIDTH	DEPTH	HEIGHT	WIDTH	DEPTH	HEIGHT		
H-137-UA-9C	9 SETS	SEE NOTE BELOW	IN	28-3/4	34-3/16	57-1/4	22	27-1/2	42	LBS	207
			MM	730	870	1455	560	700	1070	KG	94

NOTES: 1. Pan sizes 22" x 20" (560 x 510) Roast & Bake Pans, 10" x 20" (255 x 510) Roast & Bake Pans, 18" x 26" (460 x 660) Bun Pans, 14" x 18" (355 x 460) Service Trays, 12" x 20" (305 x 510) Steam Table Pans.
Refer to Pan Size Chart at end of section.

2. When ordering bumpers, add 2" to overall dimensions.

ALL ALUMINUM CONSTRUCTION IS RIVETED, WELDED AND FINISHED.

CABINET:

- Body: .063 aluminum.
- Reinforcement: Internal framework of 18 ga. stainless steel.
- Insulation: Fiberglass, thermal conductivity (K factor) is .23 at 75°F. 1-1/2" in door, base, top; 2" in sidewalls.
- Air tunnel: 22 ga. stainless steel; lift-out type, mounted on back.
- Push/pull handles (2): 5" vertical; recessed.
- Interior coved corners.

BASE:

- One piece construction, .125 aluminum.
- Casters: 5" dia., swivel, modulus tires, 1-1/4 wide, load cap. 250 lbs. each, temp. range -45°/+180°F. Delrin bearings. Front casters equipped with brakes.

DOOR:

- Field reversible.
- Exterior: .063 brushed aluminum.
- Interior: 22 ga. stainless steel.
- Latch: Positive transport type with lock hasp.
- Extruded handle.
- Hinges: Self closing, stays open past 90°.
- Gasket: Perimeter type, magnetic Santoprene.
- Pan stop.

PAN SLIDES:

- Wire angles (.306 dia.), nickel chrome plated steel, mounted on lift-off posts.
- Spaced on 4-1/2" centers; adjustable on 1-1/2" centers.

HOT UNIT COMPONENTS:

- Top mounted; removable with tools.
- Thermostat: Mechanical, room ambient to 200°F (93°C).
- Switch: ON-OFF rocker type.
- Power light.
- Power cord: Permanent, 10 ft., 14/3 ga.
- Heater: 1470 Watts.
- Blower motor.
- Vent fan.
- Thermometer: Analog

POWER REQUIREMENTS:

- 1500 Watts, 120 Volts, 60 Hz., single phase, 12 Amps., 15 Amp. service.

SHORT FORM SPECIFICATIONS

Cres Cor Insulated Hot Cabinet Model H-137-UA-9C. Inner, outer and top liners of .063 aluminum, stainless steel internal frame. (9) sets wire universal angles for multiple pan sizes, adjustable spacing every 1-1/2". Field reversible door, outer .063 brushed aluminum, inner 22 ga. stainless steel. Fiberglass insulation in sides 2"; doors, top, base 1-1/2". Interior coved corners. Hose out cleaning capability. 1500 Watt, 120 Volt power unit. One piece insulated base, .125 aluminum. 5" swivel modulus casters, Delrin bearings. Load capacity 250 lbs. each. 2 year parts warranty. Provide the following accessories: _____ . NSF, CSA-US, CSA-C, ENERGY STAR Qualified.



5925 Heisley Road • Mentor, OH 44060-1833
Phone: 877/CRESCOR • Fax: 440/350-7267
www.crescor.com

© Crescent Metal Products, Inc. 2010 All rights reserved.

In line with its policy to continually improve its products, CRES COR reserves the right to change materials and specifications without notice.